

Seibu + System 3R tooling

Ledger for Reference elements and 3Rulers



This ledger is only to guide suitable length of reference elements and 3Ruler for specific machine model. Contents for 3Rulers and/or reference elements, see also TPS-sheets covering the range of 3R-200.yyJ-x, 3R-239-xxx and accessories.

Seibu

Model	Tooling configuration for X-axis		Tooling configuration for Y-axis		MIC-xxxx	
	Ref. element	3R-239-xxx	Ref. element	3R-239-xxx		
M25LP	3R-200.24J-2	295	3R-200.39J-2	295	2881	Page: 3
M35B	3R-200.3J-1	395	3R-200.5J-2	N.a.	2865	Page: 4
M50B	3R-200.4J-61	545	3R-200.49J-1	N.a.	2866	Page: 5
M75B	3R-200.5J-2	795.86	3R-200.44J-1	N.a.	2867	Page: 6
MM35B	3R-200.24J-2	395	3R-200.44J-1	N.a.	2868	Page: 7
MM50B	3R-200.4J-61	545	3R-200.5J-2	395	2869	Page: 8
MM75B	3R-200.49J-1	795.86	3R-200.44J-1	545	2870	Page: 9
MM80B	3R-200.29J-2	845.86	3R-200.44J-1	650.86	2953	Page: 10
UMM50B	3R-200.4J-61	545	3R-200.5J-2	395	2869	Page: 8

System 3R

MIC – Machine Interface Configuration

April 12, 2019

Subject to modifications
MIC-2881

Seibu – M25LP

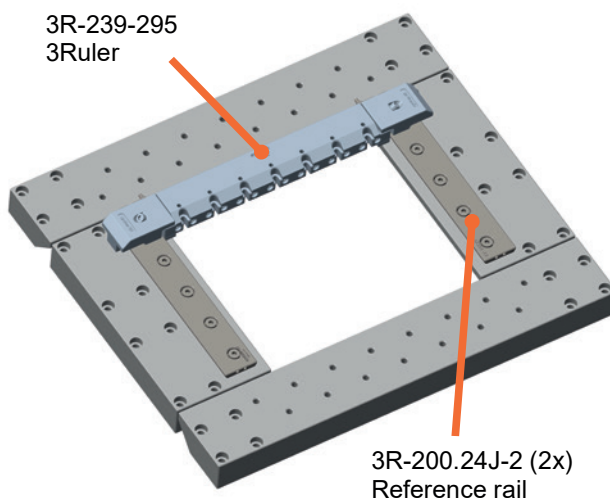

Machine table without tooling

Working area:
X: 250 mm
Y: 250 mm

Horizontal configuration

This configuration display one 3Ruler, but two cross bars may be used.

Working area:
X: 250 mm
Y: 202 mm

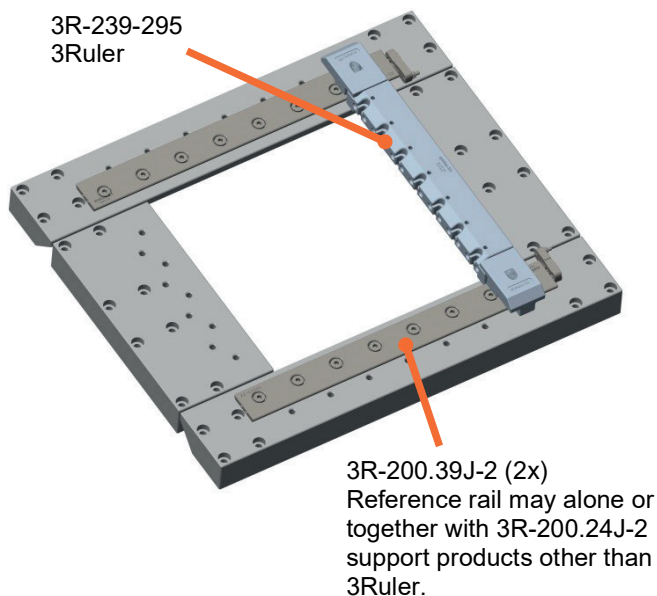

Vertical configuration

This configuration display one 3Ruler, but two cross bars may be used.

Working area:
X: 250 mm
Y: 250 mm

See also TPS-sheet "3R-239-xxx" covering 3Ruler and recommended accessories.

Note: The reference rail also enables the use of other products like: 3R-218-S, 3R-243.2-1 or 3R-272HP.

System 3R

MIC – Machine Interface Configuration

December 4, 2018

Subject to modifications
MIC-2865

Seibu – M35B

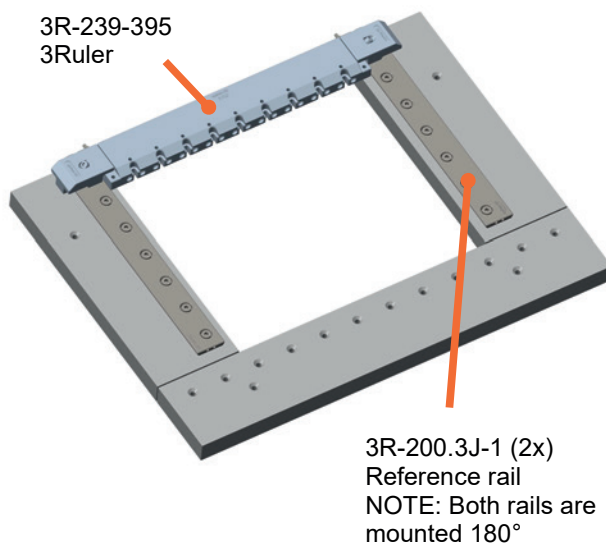

Machine table without tooling

Working area:
X: 350 mm
Y: 250 mm

Horizontal configuration

This configuration display one 3Ruler, but two cross bars may be used.

Working area:
X: 350 mm
Y: 250 mm

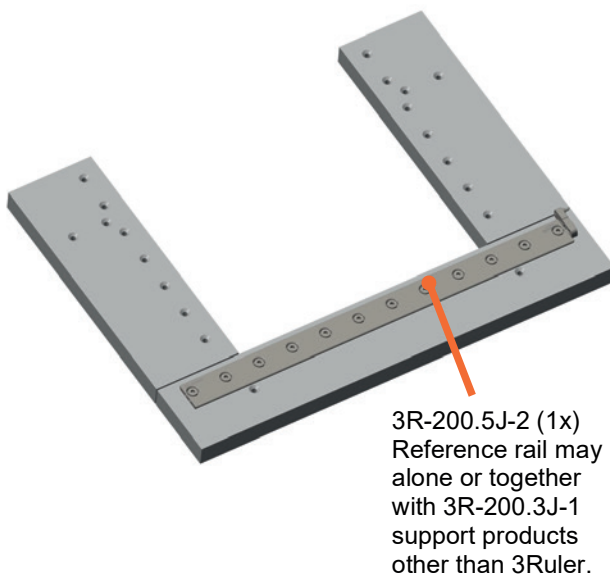

Vertical configuration

This U-shaped machine-table, does not support 3Ruler.

Working area:
X: 350 mm
Y: 250 mm

See also TPS-sheet "3R-239-xxx" covering 3Ruler and recommended accessories.

Note: The reference rail also enables the use of other products like: 3R-218-S, 3R-243.2-1 or 3R-272HP.

MIC – Machine Interface Configuration

December 4, 2018

Subject to modifications
MIC-2866

Seibu – M50B

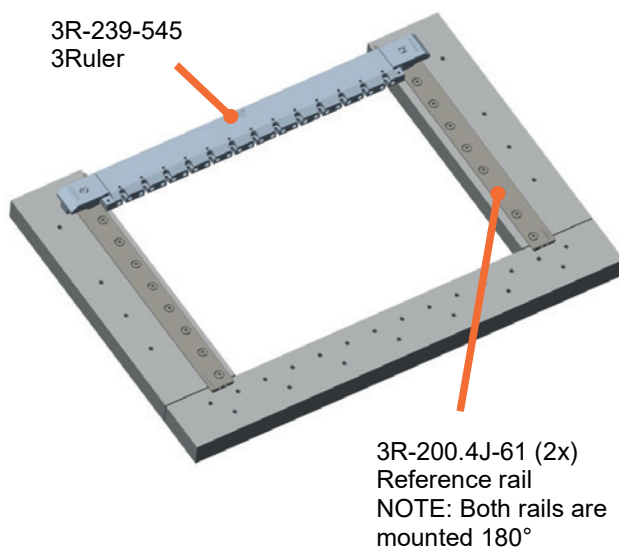

Machine table without tooling

Working area:
X: 500 mm
Y: 350 mm

Horizontal configuration

This configuration display one 3Ruler, but two cross bars may be used.

Working area:
X: 500 mm
Y: 350 mm

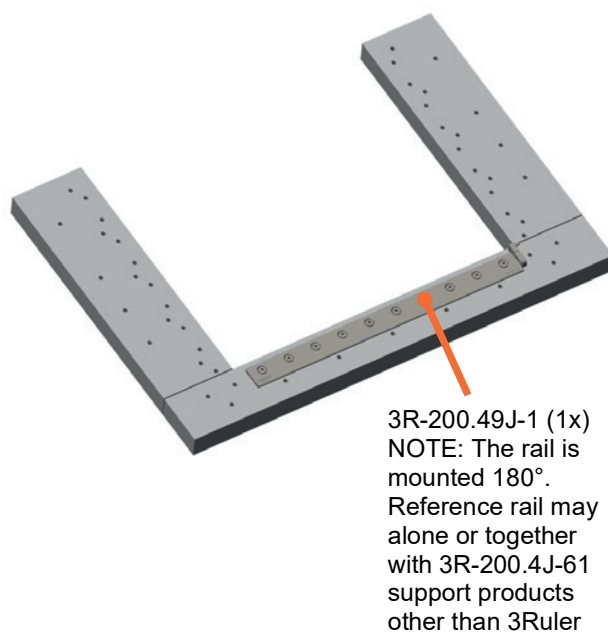

Vertical configuration

This U-shaped machine-table, does not support 3Ruler.

Working area:
X: 500 mm
Y: 350 mm

See also TPS-sheet "3R-239-xxx" covering 3Ruler and recommended accessories.

Note: The reference rail also enables the use of other products like: 3R-218-S, 3R-243.2-1 or 3R-272HP.

MIC – Machine Interface Configuration

December 4, 2018

Subject to modifications
MIC-2867

Seibu – M75B

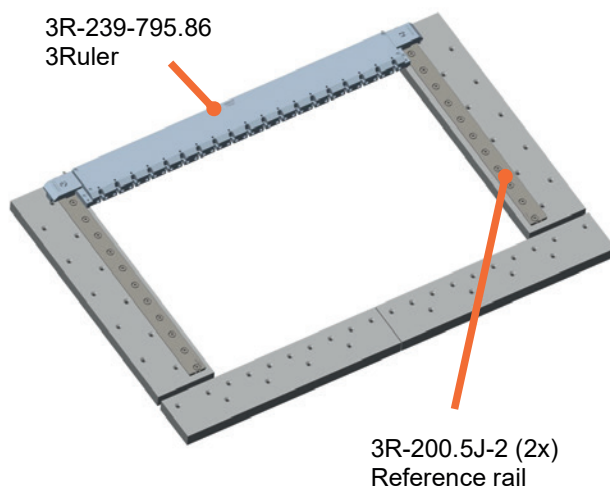

Machine table without tooling

Working area:

X: 750 mm

Y: 500 mm

Horizontal configuration

This configuration display one 3Ruler, but two cross bars may be used.

Working area:

X: 750 mm

Y: 499 mm

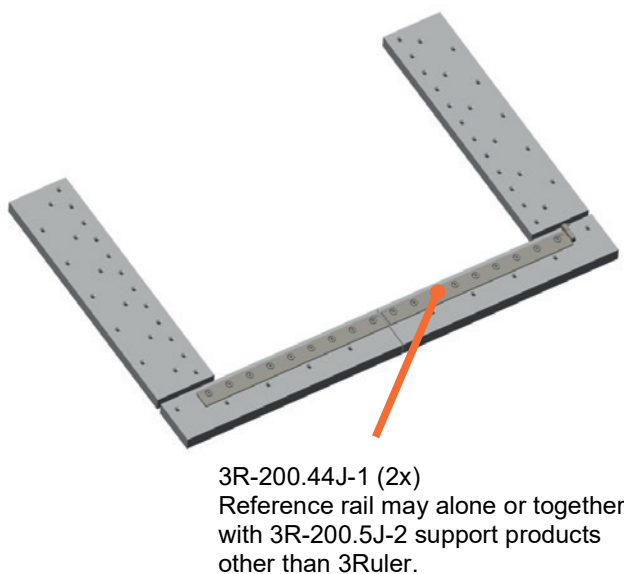

Vertical configuration

This U-shaped machine-table, does not support 3Ruler.

Working area:

X: 750 mm

Y: 500 mm

See also TPS-sheet "3R-239-xxx" covering 3Ruler and recommended accessories.

Note: The reference rail also enables the use of other products like: 3R-218-S, 3R-243.2-1 or 3R-272HP.

MIC – Machine Interface Configuration

December 6, 2018

Subject to modifications
MIC-2868

Seibu – MM35B

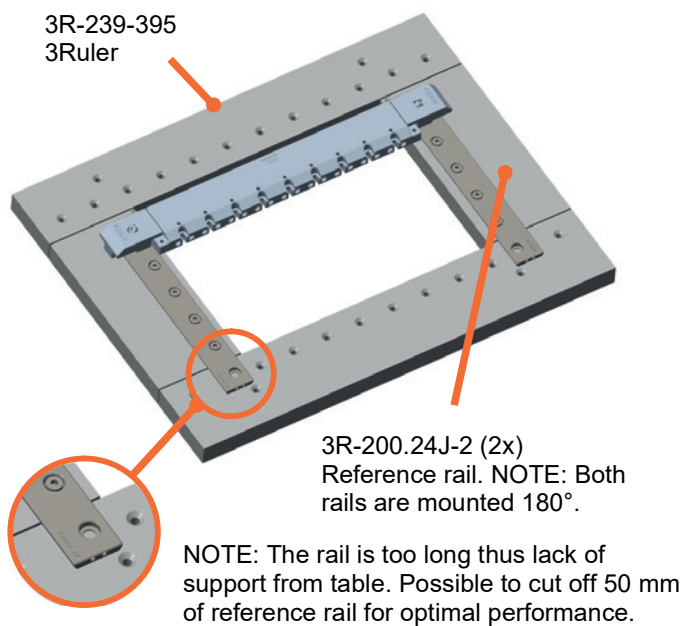

Machine table without tooling

Working area:
X: 350 mm
Y: 250 mm

Horizontal configuration

This configuration display one 3Ruler, but two cross bars may be used.

Working area:
X: 350 mm
Y: 174 mm

No suitable 3Ruler is made available

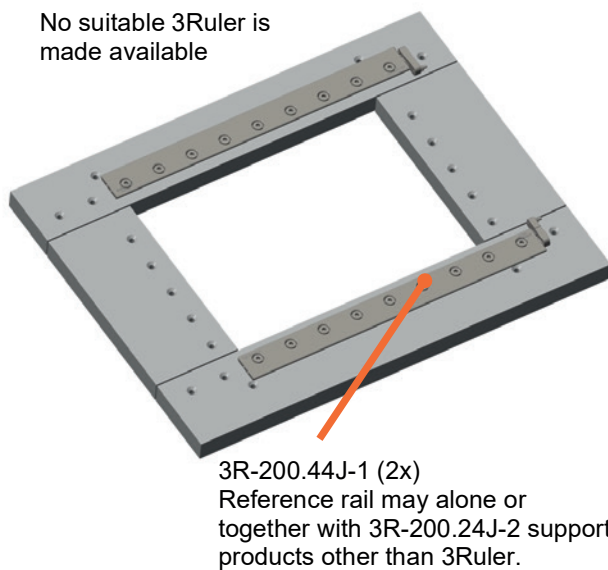

Vertical configuration

This configuration display one 3Ruler, but two cross bars may be used.

Working area:
X: 350 mm
Y: 250 mm

See also TPS-sheet "3R-239-xxx" covering 3Ruler and recommended accessories.

Note: The reference rail also enables the use of other products like: 3R-218-S, 3R-243.2-1 or 3R-272HP.

System 3R

MIC – Machine Interface Configuration

December 6, 2018

Subject to modifications
MIC-2869

Seibu – MM50B, UltraMM50B

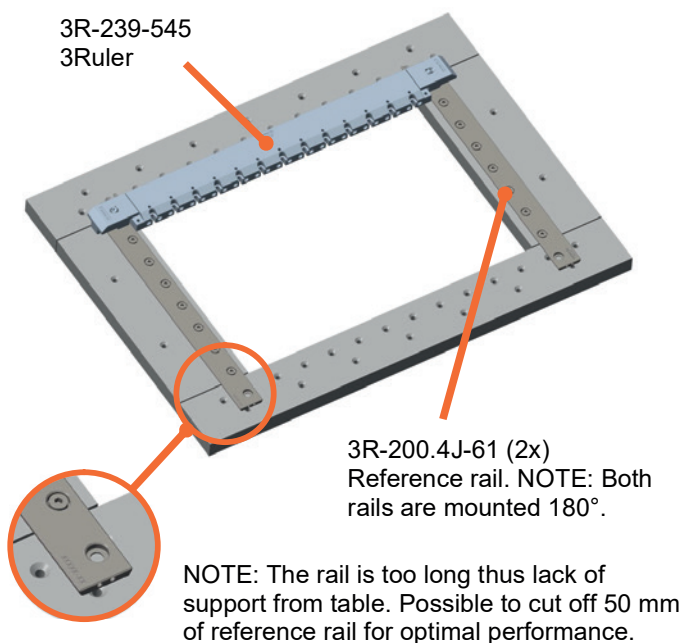

Machine table without tooling

Working area:

X: 500 mm

Y: 350 mm

Horizontal configuration

This configuration display one 3Ruler, but two cross bars may be used.

Working area:

X: 500 mm

Y: 312 mm

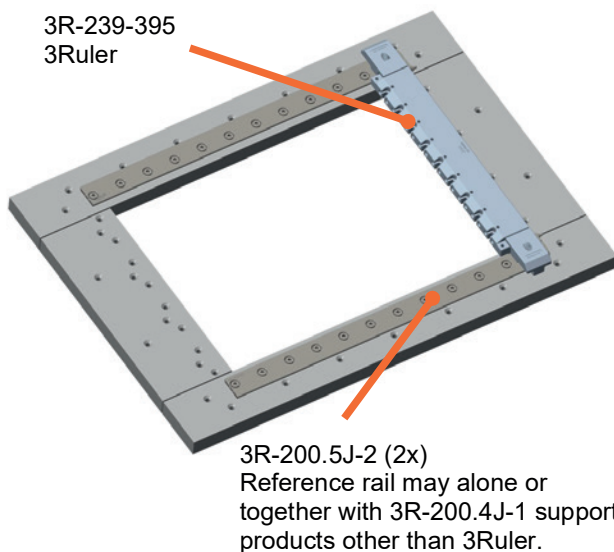

Vertical configuration

This configuration display one 3Ruler, but two cross bars may be used.

Working area:

X: 475 mm

Y: 350 mm

See also TPS-sheet "3R-239-xxx" covering 3Ruler and recommended accessories.

Note: The reference rail also enables the use of other products like: 3R-218-S, 3R-243.2-1 or 3R-272HP.

MIC – Machine Interface Configuration

December 5, 2018

Subject to modifications
MIC-2870

Seibu – MM75B

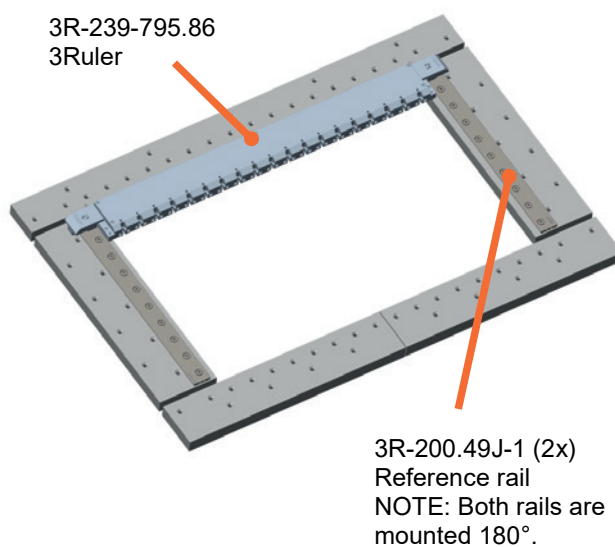

Machine table without tooling

Working area:
X: 750 mm
Y: 500 mm

Horizontal configuration

This configuration display one 3Ruler, but two cross bars may be used.

Working area:
X: 750 mm
Y: 411 mm

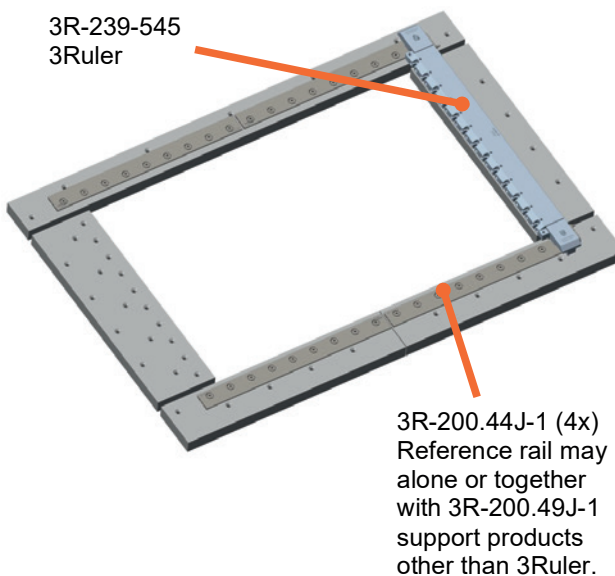

Vertical configuration

This configuration display one 3Ruler, but two cross bars may be used.

Working area:
X: 750 mm
Y: 500 mm

See also TPS-sheet “3R-239-xxx” covering 3Ruler and recommended accessories.

Note: The reference rail also enables the use of other products like: 3R-218-S, 3R-243.2-1 or 3R-272HP.

MIC – Machine Interface Configuration

July 30, 2019

Subject to modifications
MIC-2853

Mitsubishi – MX600

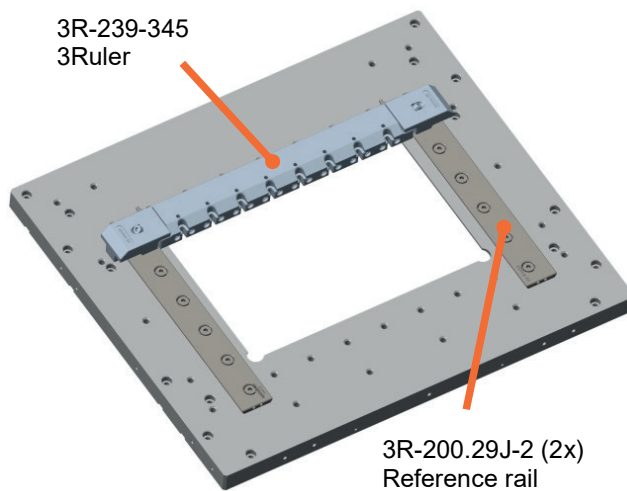

Machine table without tooling

Working area:
X: 300 mm
Y: 200 mm

Horizontal configuration

This configuration display one 3Ruler, but two cross bars may be used.

Working area:
X: 300 mm
Y: 179 mm

No 3Ruler has been made available for vertical configuration.

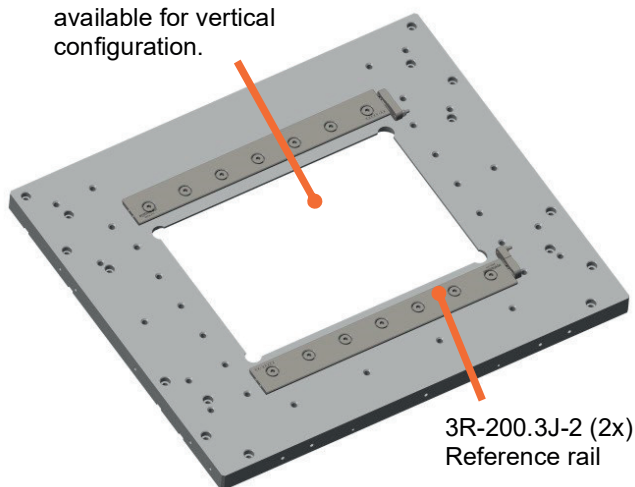

Vertical configuration

The size of table does not support Ruler by vertical configuration.

Working area:
X: 300 mm
Y: 200 mm

See also TPS-sheet "3R-239-xxx" covering 3Ruler and recommended accessories.

Note: The reference rail also enables the use of other products like: 3R-218-S, 3R-243.2-1 or 3R-272HP.

