

Mikron

HSM

500



Becoming better every day – since 1802

GF Machining Solutions

When all you need is everything, it's good to know that there is one company that you can count on to deliver complete solutions and services. From unmatched Electrical Discharge Machining (EDM), Laser texturing, Laser micromachining, Additive Manufacturing and first-class Milling and Spindles to Tooling and Automation, all of our solutions are backed by unrivaled Customer Services and expert GF Machining Solutions training. Our AgieCharmilles, Microlution, Mikron Mill, Liechti, Step-Tec and System 3R technologies help you raise your game—and our digital business solutions for intelligent manufacturing, offering embedded expertise and optimized production processes across all industries, increase your competitive edge.



+ We are Mikron Mill.
We are GF Machining Solutions.

Contents

4	Applications
6	Highlights
7	Machine base
9	Accuracy
10	With high speed to EDM
11	Applications in graphite
13	smart machine
14	Options for all needs
15	Customer services

16	Technical data
18	GF Machining Solutions

High speed milling has never been so easy...

Mikron's HSM 500: The unique concept of the HSM line designed to meet mold- and toolmakers requirements.

No compromises

Highest accuracy, extreme dynamic and best surface quality. Incomparable accessibility, best ergonomics, and a user friendly handling of the machine.

Consistent quality

Every machining centre "made by Mikron" has been assembled in our air-conditioned assembly shops by qualified personnel. Inspecting according to ISO 230/97, extensively testing to meet quality goals.

The results are logged and handed over with the machine to the customer.

GF Machining Solutions

Applications

As flexible as your production is...

Thin walled part

Material Aluminum
Time 27 min.
Machine HSM 500



Bottle mold

Material 1.2316
Hardness 35 HRC
Priority Surface
Time 420 min.
Machine HSM 500

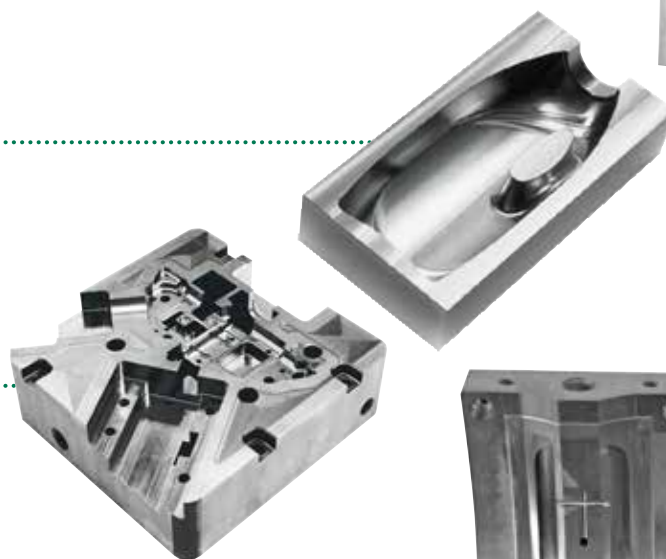

Mold core

Material 1.2379
Hardness HRC 58
Priority Precision
Time 288 min.
Machine HSM 500

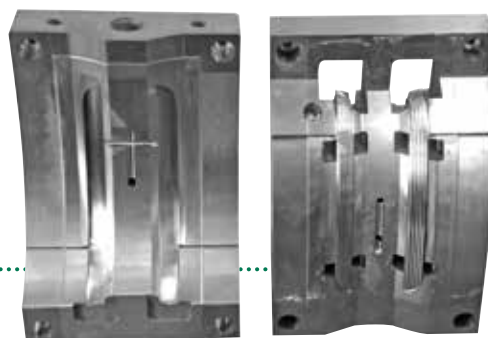

Car light mold

Material Assab S136
Hardness HRC 50
Time 240 min. per cavity
Machine HSM 500



Mobile phone mold

Material NAK 80
Hardness 40 HRC
Time 416 min.
Machine HSM 500

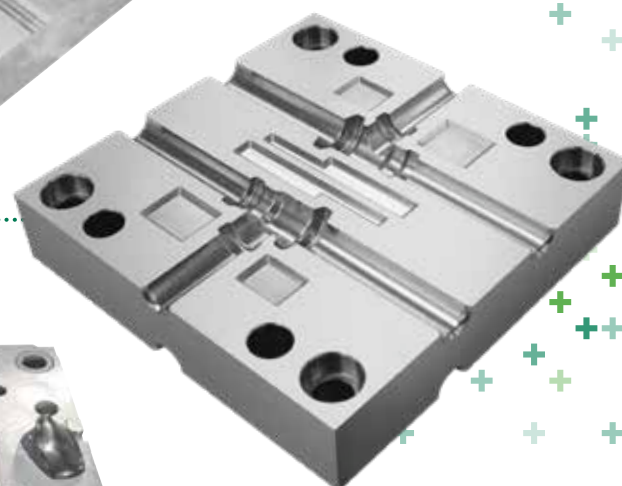

Hot pressing die for fittings

Material 1.2344
Hardness 25 HRC
Time 216 min.
Machine HSM 500



Car antennas mold

Material Assab S136
Hardness HRC50
Time 60 min. per cavity
Machine HSM 500



Highlights

Precision and quality for tool and mold making

Trapezoidal window for a clear view of the machining process



Dynamic tool spindle with vector regulation and ceramic-hybrid bearings

Effortless crane loading



Protected tool magazine and tool measurement area.

One sliding door with a large window

Powerful machine control system



Full table size available for work

Integrated tank and chip management



Software modules for efficient, controlled working

GF Machining Solutions machining centers feature extraordinary ergonomics. Unparalleled accessibility regardless of the respective machine configuration.

Sophisticated concept for maximum rigidity

Pyramid-shaped design

The pyramid-shaped arrangement ensures stability and rigidity.

Closed structure

The O-shaped portal increases the structural dampening characteristics

Cross slide

The cross slide is weight-optimised to meet highly dynamic machine tool motion requirements.

Polymer cast machine base

Portal construction for high rigidity and compact foot-print.

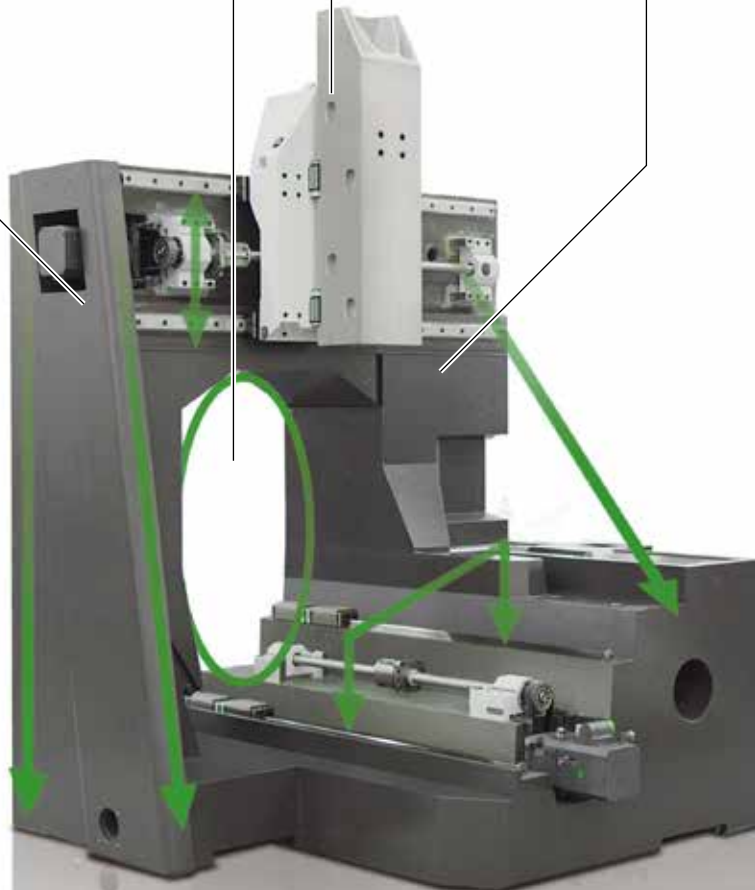

Polymer concrete

Striking features of polymer concrete include high thermal resistance and outstanding damping characteristics. It is not susceptible to oil or cooling lubricants and does not undergo an aging process.

Up to 6 times better damping characteristics than grey cast iron.

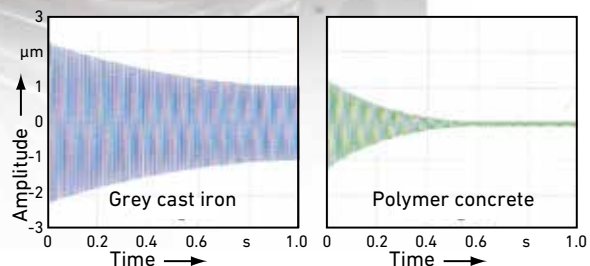



Step-Tec
Switzerland

Accuracy

Maximum accuracy...

...through optical linear scales, cooled drives and consistent quality control

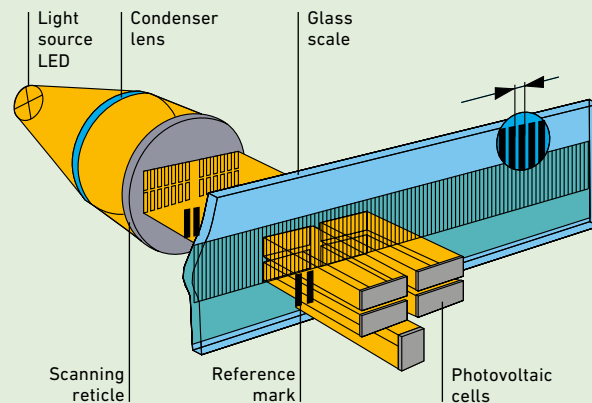

Accuracy

Precision as a standard ...

- + Absolute optical linear scales on X, Y, and Z axis operating with a measuring step of 20 nanometers for incomparable positioning precision
- + Better thermal inertia of machine base due to the polymer concrete
- + All feed motors, the electrical cabinet and the motor spindle are liquid-cooled
- + Highly accurate probing

High speed spindle

A key factor in a high speed milling machine...

- + Vector controlled motor spindle for short run-up and brake times and high torques at low speed
- + Ceramic hybrid ball bearings with oil-air minimal lubrication
- + Liquid-cooled stator jacket and bearings
- + HSK interface



Automatic central lubrication

The automatic central lubrication system supplies the recirculating ball screws and the linear guides with grease at precisely defined intervals. This increases the service life of the feed units and reduces maintenance costs.

Touch probe

A compact and extremely accurate touch probe is available as a standard option.

- + Easy set-up
- + In process calibration
- + Measurement in the machine



Quality control

Every MIKRON HSM machine is validated in our air-conditioned assembly shop with highly accurate laser measuring systems.



Water-cooled

All heat sources in MIKRON HSM machines are as standard watercooled.

- + Drives
- + High speed spindle
- + Electrical cabinet

Mikron HSM 500 Graphite

With high speed to EDM

Graphite electrodes, like high-speed machines, are both designed to increase productivity and customer values. The high speed milling of graphite electrodes requires not only a high reliability and performance spindle, it also requires exceptional vibration damping and repeating machine accuracy.

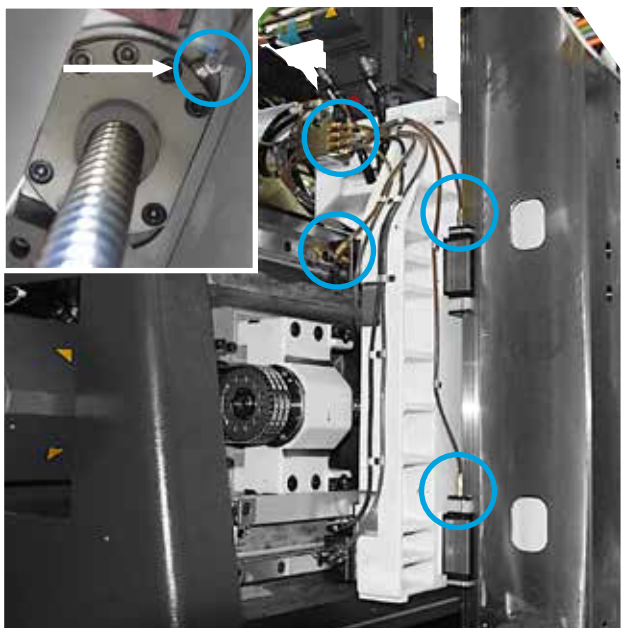

Advantages

- + Absolute optical linear scales on X, Y, and Z axis operating with a measuring step of 0.02 guarantees incomparable positioning precision
- + Better thermal inertia of machine base due to the polymer concrete
- + All feed motors, the electrical cabinet and the motor spindle are liquid-cooled
- + No heat source in the machines structure

Vacuum removal of graphite

- + All axis fully covered and protected (machine hood)
- + Automatic central lubrication with grease on all linear guides and ball screws
- + Powerful Amano suction unit with two separate dust bins

High speed spindle

- + Maximum operating speed 42.000 rpm
- + Vector controlled motor spindle for short run-up and brake times and high torques at low speed
- + Ceramic hybrid ball bearings with oil-air minimal lubrication
- + Liquid-cooled stator jacket and bearings
- + HSK interface

Applications in graphite

Efficient production in universal applications

Material: Graphite R8710

		Diameter D [mm]	Spindle speed n [rpm]	Feed rate v_f [mm/min]	Radial cutting depth a_e [mm]	Axial cutting depth a_p [mm]	Machining time t [min]
Operation	Tool						
Roughing	toric	6	22'000	4'000	4	0.5	6 min
Prefinishing	toric	3	30'000	2'500	2	0.3	7 min
Roughing	toric	1.5	30'000	2'000	1	0.2	21 min
Prefinishing	ball nose	1	30'000	1'800	0.2	0.05	29 min
Finishing	ball nose	0.6	30'000	1'500	0.1	0.1	5 min
Total							68 min

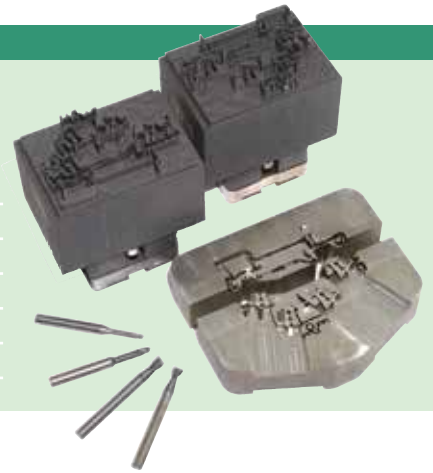

Material: Graphite R8710

		Diameter D [mm]	Spindle speed n [rpm]	Feed rate v_f [mm/min]	Radial cutting depth a_e [mm]	Axial cutting depth a_p [mm]	Machining time t [min]
Operation	Tool						
Roughing	toric	6	18'000	4'000	2.5	0.5	3.5 min
Prefinishing	toric	2	27'000	2'000	1.5	0.5	1 min
Roughing	ball nose	1	30'000	800	--	0.2	6 min
Finishing	ball nose	0.6	30'000	500	--	0.08	14 min
Slotting	toric	0.3	30'000	500	0.03	0.03	1.5 min
Total							26 min



Material: Graphite R8710

		Diameter D [mm]	Spindle speed n [rpm]	Feed rate v_f [mm/min]	Radial cutting depth a_e [mm]	Axial cutting depth a_p [mm]	Machining time t [min]
Operation	Tool						
Roughing	toric	6	20'000	6'000	3.5	1.5	8 min
Prefinishing	ball nose	2	29'000	3'500	0.5	0.4	5 min
Roughing	ball nose	1	30'000	2'000	0.08	0.08	8 min
Finishing	ball nose	1	30'000	4'000	0.05	0.05	29 min
Total							50 min



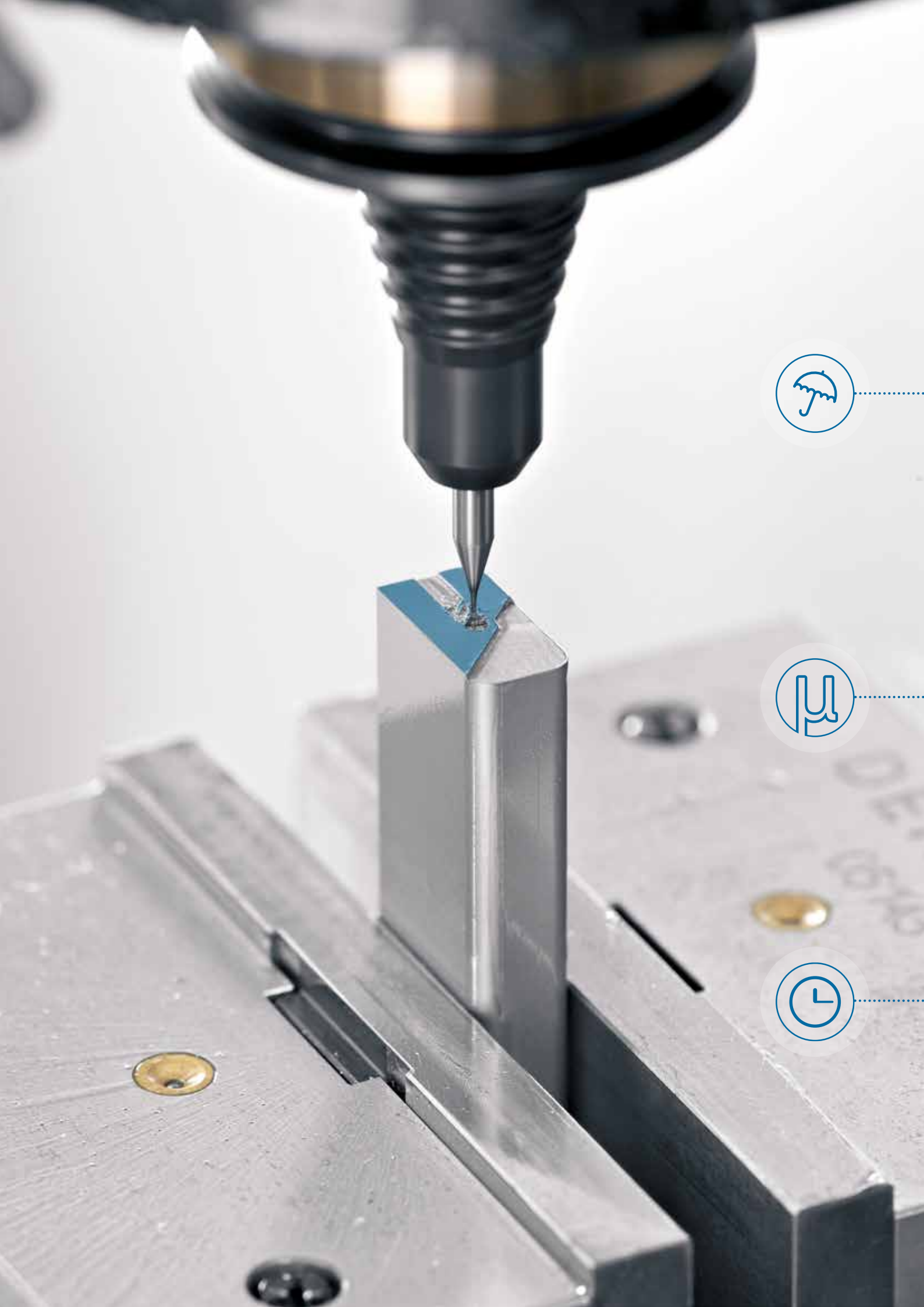

Brings intelligence into the milling process

Advanced Process System

Protection

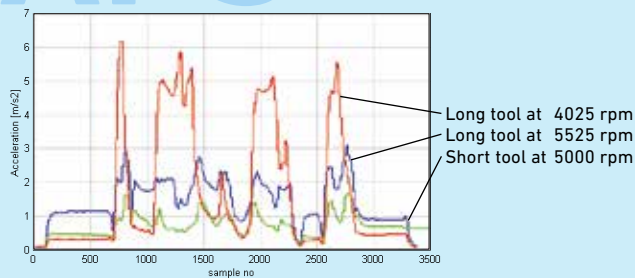

The unique vibration monitoring system

With the help of this system, vibrations that occur during a milling process can be made visible as a “G-load”. So it is possible to intervene selectively in the process and optimise it.

Your benefit

- + Increase the life-time of the spindle (reduction in the machine’s hourly rate)
- + Improve quality (Recognition of critical machining strategies)
- + Increased tool life (Improvement over all process reliability and cost)

Intelligent Thermal Control

Precision

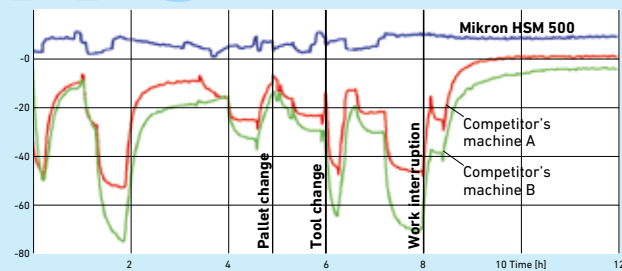

The unique in-process compensation

Usually, the machine operator has to wait for the machine to settle to a thermal steady-state for a couple of hours. With the Intelligent Thermal Control, the operator can directly start with precision work. The machine actively compensates for thermal displacement of the tool center point. Excellent accuracy is the result on the workpiece.

Your benefit

- + Higher productivity
- + Higher accuracy
- + Increased process reliability

Operator Support System

Productivity



Time, Surface, Accuracy

The operator can access the internal parameters of the CNC controller using a simple and understandable interface to set the target value.

The system adjusts the dynamic behavior of the machine tool motion exactly according to your needs.

Your benefit

- + Shorter machining times
- + Better surface quality
- + Higher accuracy

Options

Options for all needs



Coolant



Rotating window



Minimum quantity lubrication



Oil mist extraction

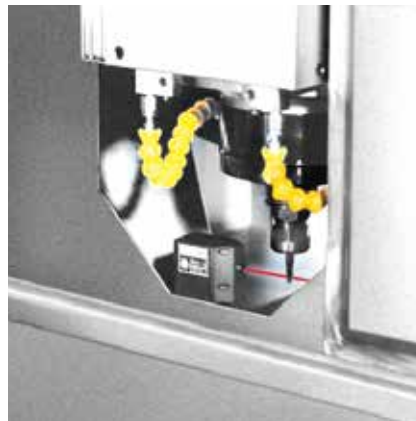

Laser tool measuring



Mobile handwheel

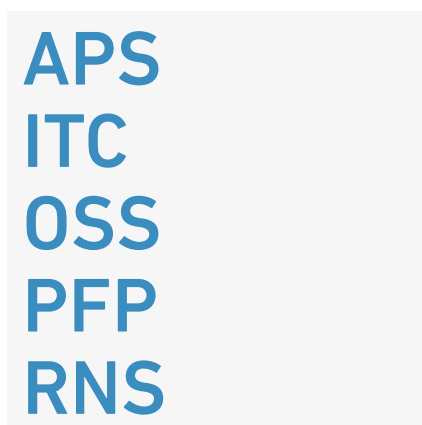

smart machine

Customer Services

New digital service possibilities

GF Machining Solutions Customer Services continues to push technological boundaries to deliver the future of services to you—today.



rConnect is the digital services platform available for all GF Machining Solutions technologies. Following a modular approach, rConnect comprises a range of services that empower you to increase your manufacturing productivity. Certified with the TÜViT Trusted Product Certificate.

rConnect Messenger, we deliver machine data to your mobile device to keep you constantly informed about your production. You can supervise your workshop from your smartphone.

rConnect Live Remote Assistance (LRA), our expert engineers rapidly respond to your service requests. LRA allows effective face-to-face assistance using audio, video, chat and many more functionalities.



Technical data



Mikron HSM 500

Workarea

Longitudinal	X	mm	500
Lateral	Y	mm	450
Vertical	Z	mm	350

Working spindle (40% ED, S6)

42,000 rpm	HSK-E40	kW / Nm	13.0/ 8.8
30,000 rpm	HSK-E40	kW / Nm	12.0/ 8.8

Feed rate

Rapid traverse	(X, Y, Z)	m / min	42
----------------	-----------	---------	----

Work table

Clamping surface	mm	550x450
Max table load	kg	200

Tool magazine

HSK-E40	Capacity	18/36
---------	----------	-------

Standard equipment

Control Heidenhain TNC 640	+
Interface Ethernet	+
25 GB Harddisk capacity	+
3 user-definable M codes	+
Step-Tec High-Speed Spindle	+
Vector drive (high torque)	+
Rigid tapping	+
Optical linear scales with compressed air protection	+
Liquid cooled spindle, drives, electrical cabinet	+

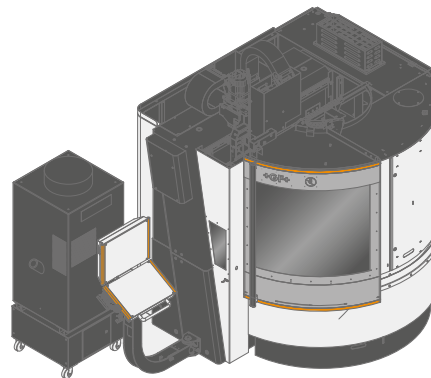
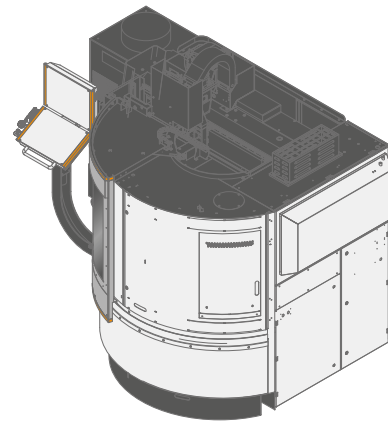
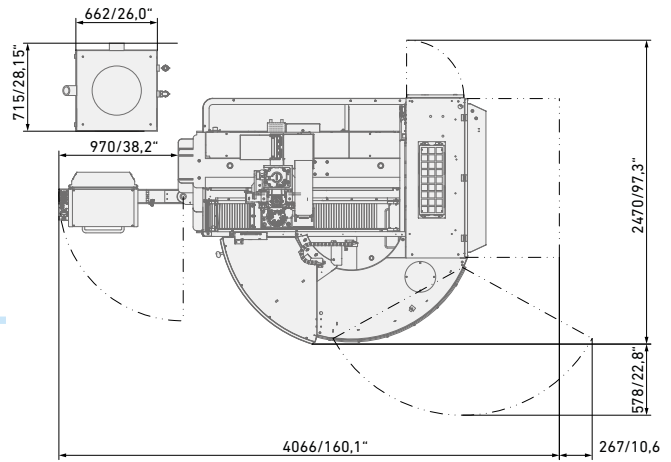
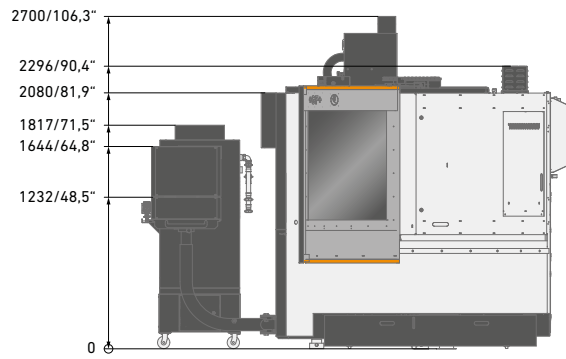
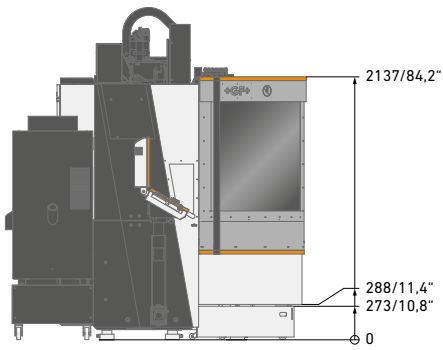

About GF Machining Solutions

Multi-technology solutions provider

Our commitment to you and your specific applications is proven by the value-adding intelligence, productivity and quality delivered by our multi-technology solutions. Your success is our chief motivator. That's why we are continuously advancing our legendary technical expertise. Wherever you are, whatever your market segment and whatever the size of your operation, we have the complete solutions and the customer-centric commitment to accelerate your success—today.

EDM (electrical discharge machining)



Wire-cutting EDM

GF Machining Solutions' wire-cutting EDM is fast, precise and increasingly energy efficient. From ultraprecise machining of miniaturized components down to 0.02 mm to powerful solutions for demanding high-speed machining with respect to surface accuracy, our wire EDM solutions position you for success.

Die-sinking EDM

GF Machining Solutions is revolutionizing die-sinking EDM with features like iGAP technology to dramatically boost machining speed and reduce electrode wear. All of our die-sinking systems offer fast removal and deliver mirror finishes of Ra 0.1 µm (4 µin).

Hole-drilling EDM

GF Machining Solutions' robust hole-drilling EDM solutions enable you to drill holes in electrically conductive materials at a very high speed—and, with a five-axis configuration, at any angle on a workpiece with an inclined surface.

Milling



Milling

Precision tool and mold manufacturers enjoy a competitive edge with our Mikron MILL S solutions' fast and precise machining. The Mikron MILL P machines achieve above-average productivity thanks to their high performance and Automation. Customers seeking fastest return on investment benefit from the affordable efficiency of our MILL E solutions.

High Performance Airfoil Machining

Our Liechti turnkey solutions enable the highly dynamic manufacturing of precision airfoils. Thanks to their unique performance and our expertise in airfoil machining, you increase productivity by producing at the lowest cost per part.

Spindles

As part of GF Machining Solutions, Step-Tec is engaged in the very first stage of each machining center development project. Compact design combined with excellent thermal and geometric repeatability ensure the perfect integration of this core component into the machine tool.

Advanced manufacturing



Laser texturing

Aesthetic and functional texturing is easy and infinitely repeatable with our digitized Laser technology. Even complex 3D geometries, including precision parts, are textured, engraved, microstructured, marked and labeled.

Laser micromachining

GF Machining Solutions offers the industry's most complete line of Laser micromachining platforms optimized for small, high-precision features to meet the increasing need for smaller, smarter parts to support today's leading-edge products.

Laser Additive Manufacturing (AM)

GF Machining Solutions and 3D Systems, a leading global provider of additive manufacturing solutions and the pioneer of 3D printing, have partnered to introduce new metal 3D printing solutions that enable manufacturers to produce complex metal parts more efficiently.

Tooling and Automation



Tooling

Our customers experience complete autonomy while maintaining extreme accuracy, thanks to our highly accurate System 3R reference systems for holding and positioning electrodes and work pieces. All types of machines can easily be linked, which reduces set-up times and enables a seamless transfer of workpieces between different operations.

Automation

Together with System 3R, we also provide scalable and cost-effective Automation solutions for simple, single machine cells or complex, multi-process cells, tailored to your needs.

Software



Digitalization solutions

To drive its digital transformation, GF Machining Solutions acquired symmedia GmbH, a company specialized in software for machine connectivity. Together, we offer a complete range of Industry 4.0 solutions across all industries. The future requires the ability to adapt quickly to continual digital processes. Our intelligent manufacturing offers embedded expertise, optimized production processes, and workshop Automation: solutions for smart and connected machines.

Customer Services



Worldwide for you

Ensuring the best performance throughout the lifetime of our customers' equipment is the goal of our three levels of support. Operations Support offers the complete range of original wear parts and certified consumables. Machine Support includes spare parts, technical support, and a range of preventive services to maximize machine uptime. Business Support offers customer-specific business solutions.



Switzerland

Biel/Bienne
Losone
Geneva
Flawil
Langnau

www.gfms.com
www.gfms.com/ch

Europe

Germany, Schorndorf
www.gfms.com/de

United Kingdom, Coventry
www.gfms.com/uk

Italy, Agrate Brianza - MI
www.gfms.com/it

Spain, Sant Boi de Llobregat
Barcelona
www.gfms.com/es

France, Palaiseau
www.gfms.com/fr

Poland, Raszyn / Warsaw
www.gfms.com/pl

Czech Republic, Brno
www.gfms.com/cz

Sweden, Vällingby
www.gfms.com/system3r

Turkey, Istanbul
www.gfms.com/tr

Americas

USA
Lincolnshire, IL
Chicago, IL
Holliston, MA
Huntersville, NC
Irvine, CA
Woodridge, IL
www.gfms.com/us

Canada, Mississauga ON
www.gfms.com/us

Mexico, Monterrey NL
www.gfms.com/us

Brazil, São Paulo
www.gfms.com/br

Asia

China
Beijing, Shanghai, Chengdu, Dongguan,
Hongkong, Changzhou
www.gfms.com/cn

India, Bangalore
www.gfms.com/sg

Japan
Tokyo, Yokohama
www.gfms.com/jp

Korea, Seoul
www.gfms.com/kr

Malaysia, Petaling Jaya
www.gfms.com/sg

Singapore, Singapore
www.gfms.com/sg

Taiwan
Taipei, Taichung
www.gfms.com/tw

Vietnam, Hanoi
www.gfms.com/sg

At a glance

We enable our customers to run their businesses efficiently and effectively by offering innovative Milling, EDM, Laser, Additive Manufacturing, Spindle, Tooling and Automation solutions. A comprehensive package of Customer Services completes our proposition.

www.gfms.com

